

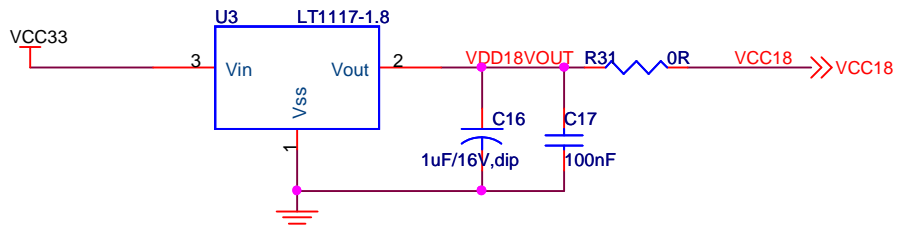

Schematics from yangchu
www.yangchu.com

Title			S3C2440 Kernel Board		
Size	Document Number		Rev		
A	1		1.0.0		
Date:	Monday, July 16, 2007		Sheet	1	of 1

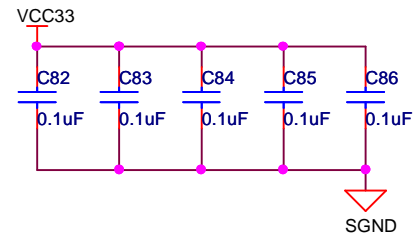

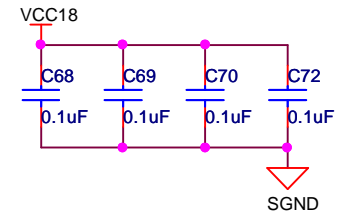
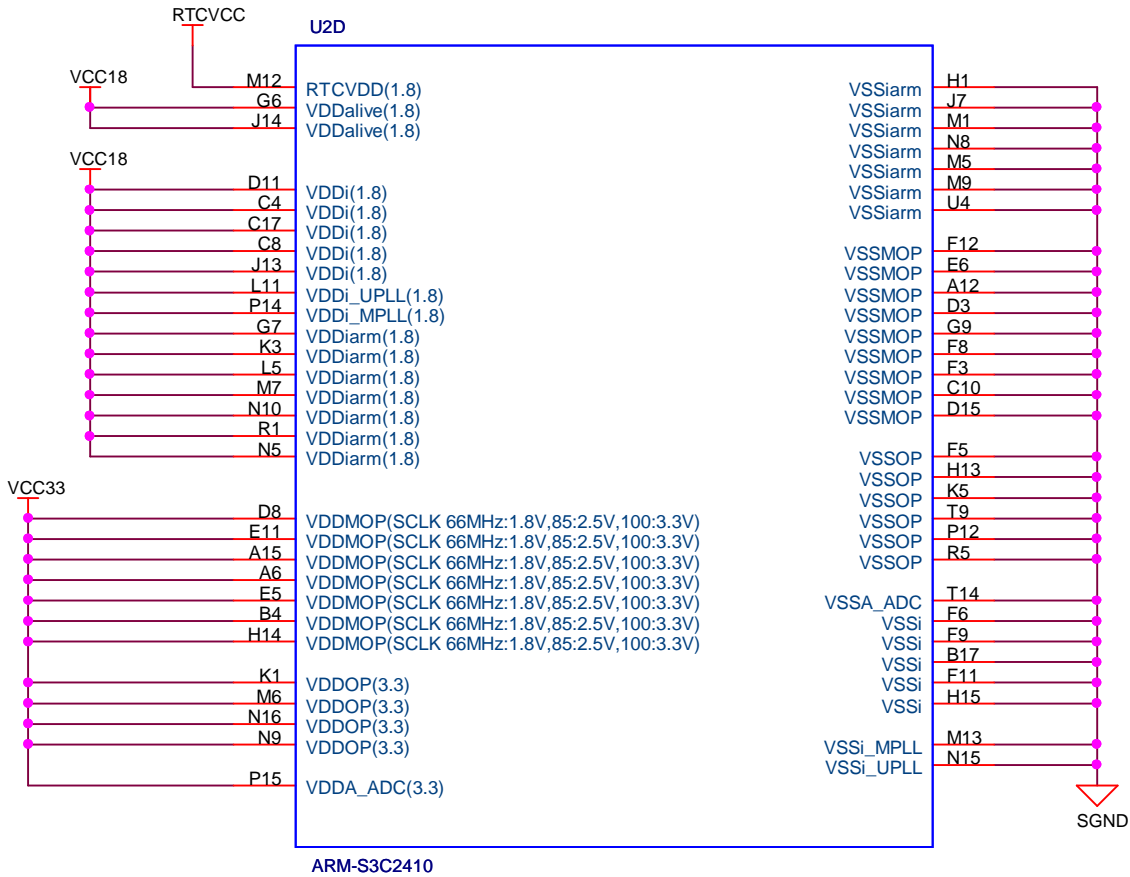

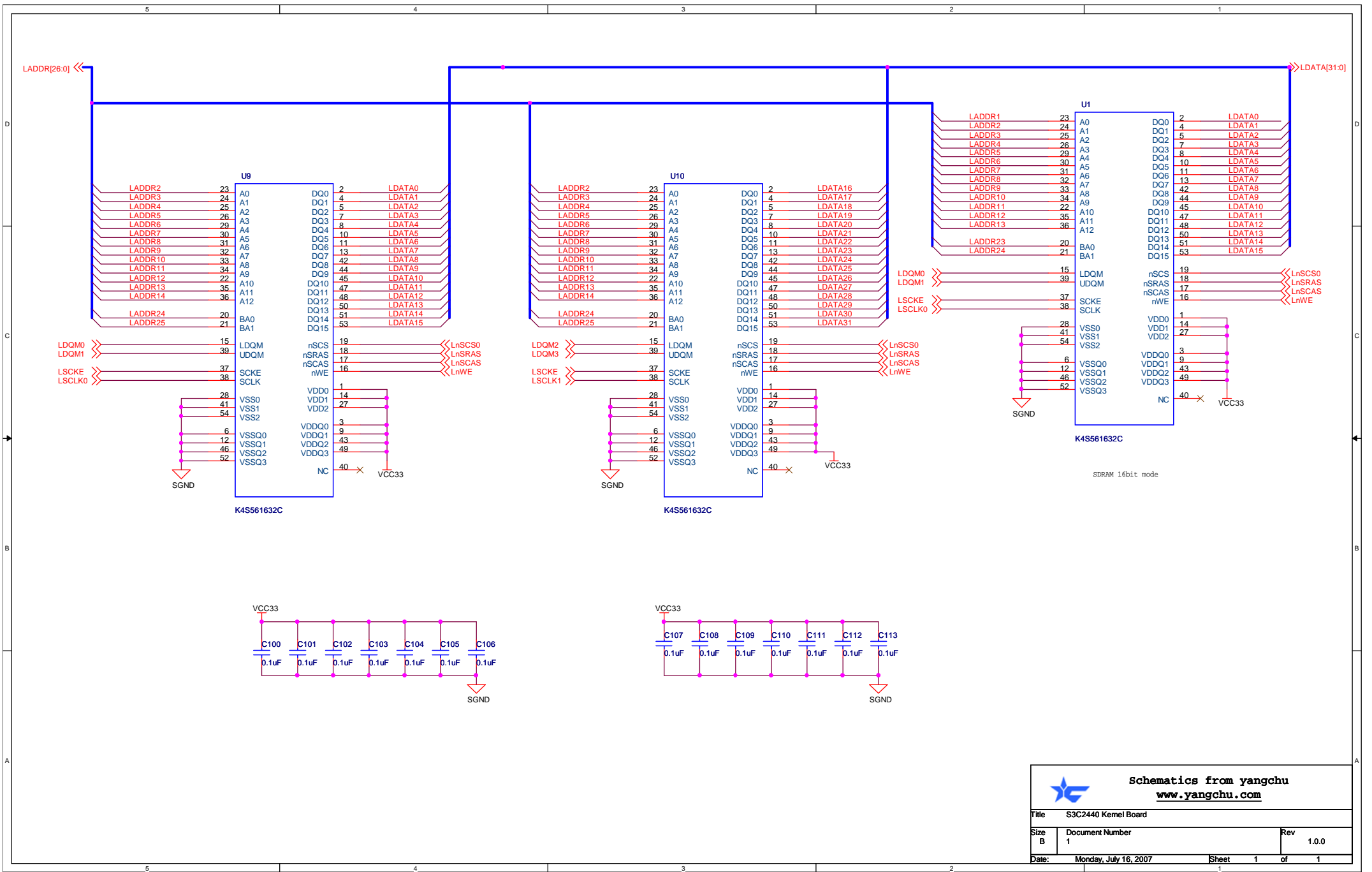
 Schematics from yangchu www.yangchu.com		
Title S3C2440 Kernel Board		
Size A	Document Number 1	Rev 1.0.0
Date: Monday, July 16, 2007	Sheet 1	of 1

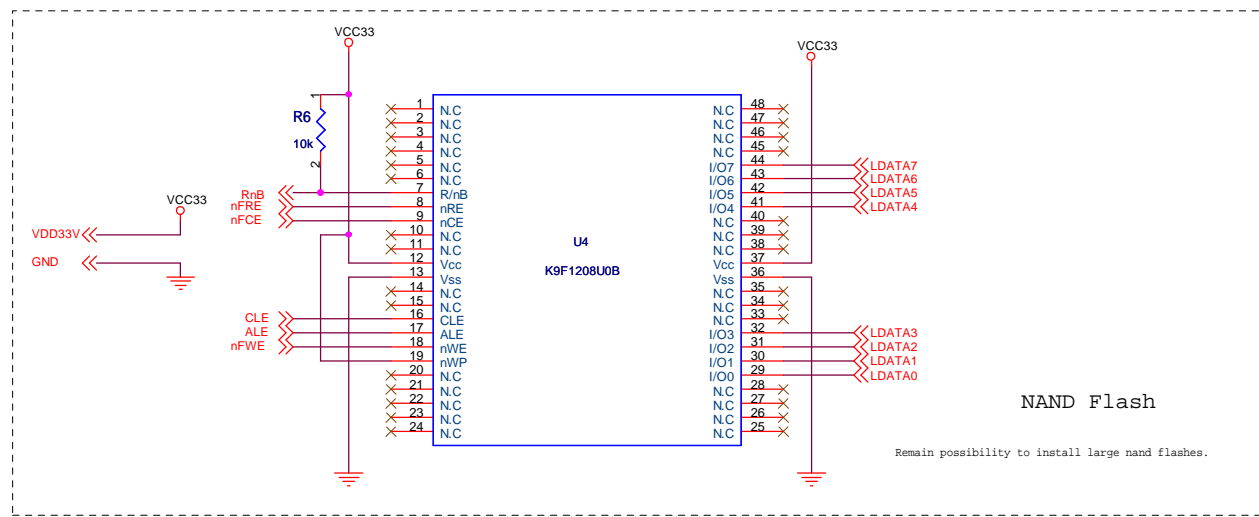
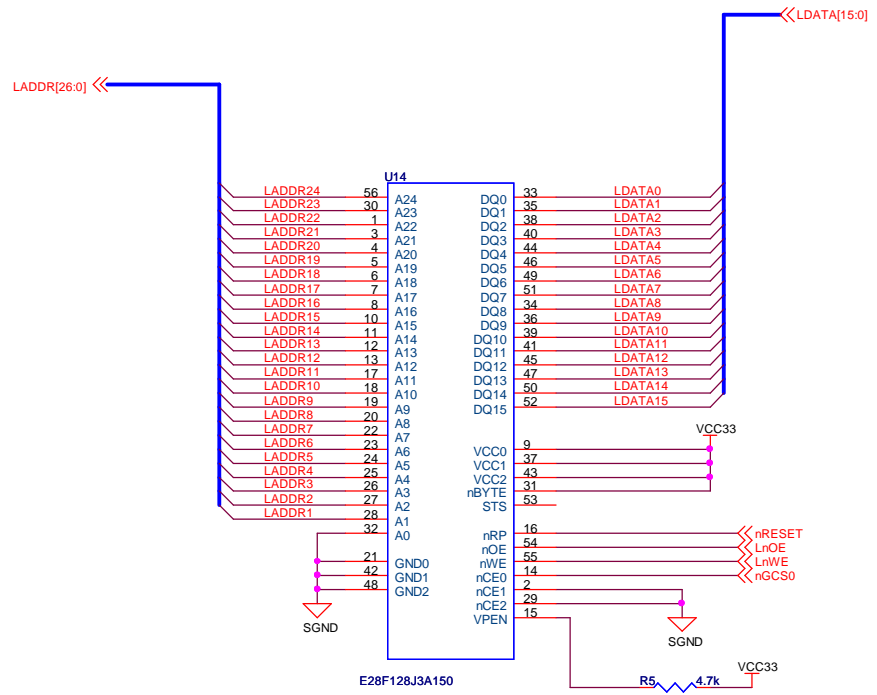

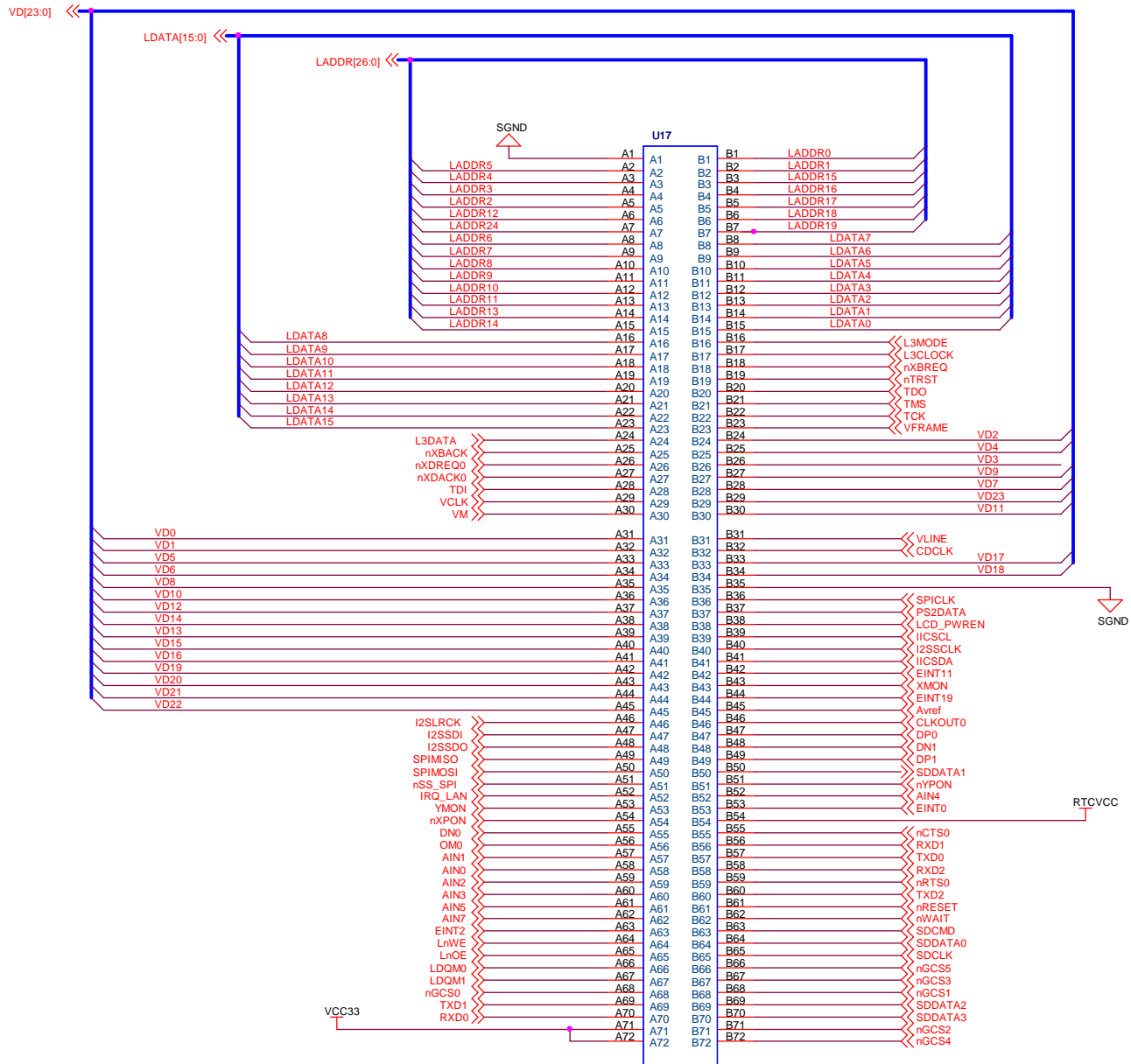

 Schematics from yangchu www.yangchu.com		
Title: SSC2440 Kernel Board		
Size: B	Document Number: 1	Rev: 1.0.0
Date: Monday, July 16, 2007	Sheet: 1	of: 1



Schematics from yangchu
www.yangchu.com

Title: S3C2440 Kernel Board		
Size: B	Document Number: 1	Rev: 1.0.0
Date: Thursday, July 26, 2007	Sheet: 1	of 1

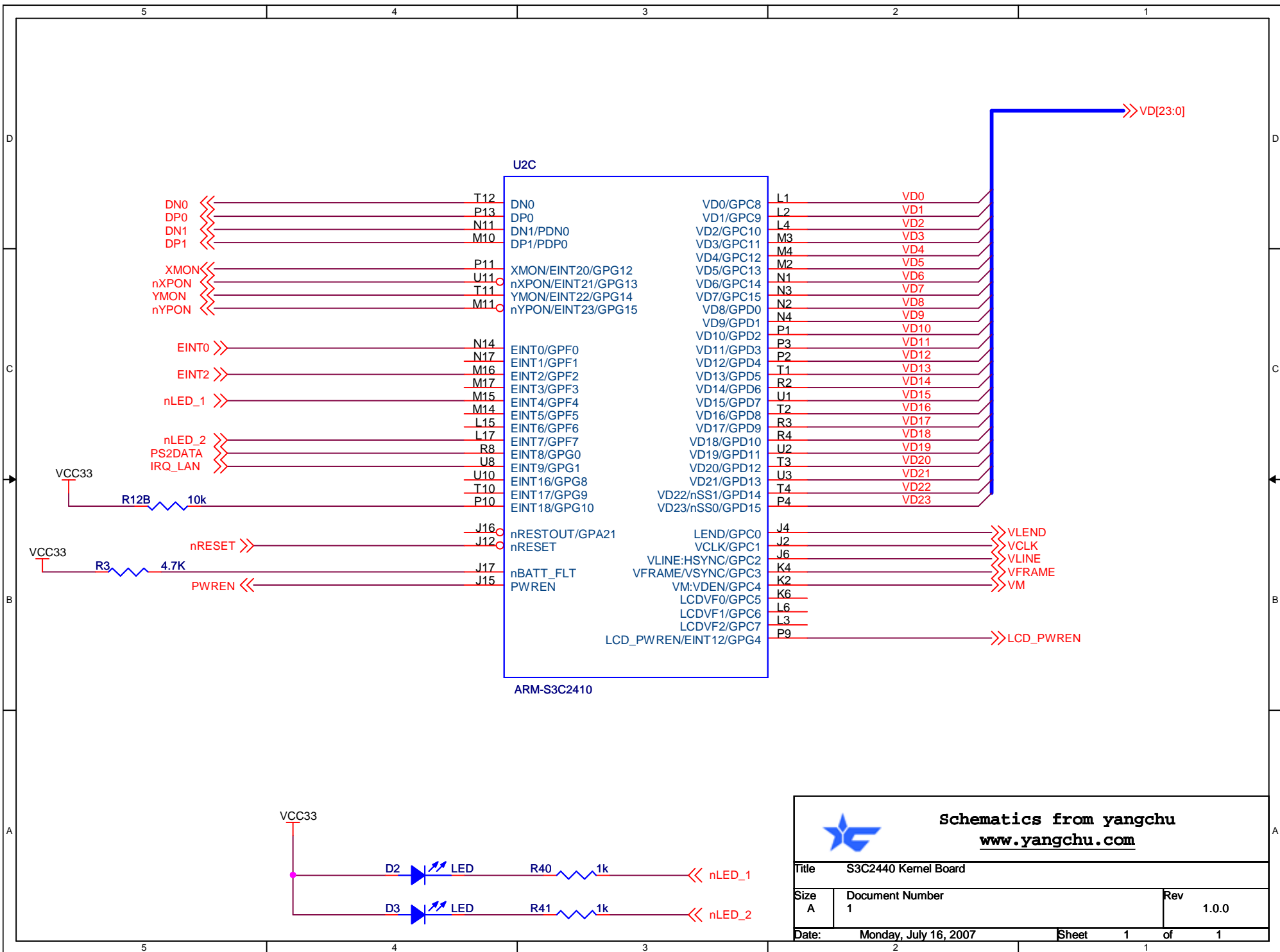

Schematics from yangchu
www.yangchu.com

Title: S3C2440 Kernel Board		
Size: A	Document Number: 1	Rev: 1.0.0
Date: Monday, July 16, 2007	Sheet: 1	of: 1